





















ELITE-INO

Endo Motor user manual

Contents

1.Symbols	1
2.Technical Data.....	2
3.Parts Identification.....	3
4.Intended use	4
5.Contraindications	4
6.Use Interface	5
7.Charging.....	9
8.Install accessories	10
9.Before Operation	14
10.Operation	18
11.User Setting	26
12.Error Warring.....	27
13.Maintenance and sterilization	28
14.Troubleshooting	31
15.EMC table	32
16.Warranty	36
17.Service life	36
18.Declaration	36
19.Environmental protection	36
20.Right.....	36
21.Warranty Card	37

1. Symbols

 Warning	If the instructions are not followed properly, operation may lead to hazards for the product or the user/patient.
 NOTE	Additional information, explanation of operation and performance.
	Do not dispose with ordinary household waste(WEEE)
	Serial number
	Catalogue number
	manufacture
	Date of manufacture
	Type B applied part
	Direct current
	Safety class II device
	Store in a dry place
	Can be autoclaved up to a maximum temperature of 135° Celsius
	Temperature limitation
	Relative humidity
	Transport and storage pressure conditions: 70 kPa - 106 kPa
	This way up
	keep away from heat
	Recyclable

2. Technical Data

Model	ELITE-INO
Package size	240 mm x 166 mm x 82mm
Package weight	Approx. 800g, $\pm 10\%$
Power supply	ICR18500, DC3.7V 1900mAh $\pm 10\%$
Charger power supply	AC100-240V, 50/60Hz
Charger nominal power input	5VA
Degree of protection	IPX 0
Electrical safety class	Class II
Applied part	B
Contra-angle	Ratio : 6: 1 Contra-angle compatible with rotary and reciprocating, equipped with a 2.35 mm shaft conforming to ISO 1797-1, Type 1, Files length 11-31mm
Torque range	0.6N.cm - 4.0N.cm
Speed range	120rpm-1000rpm
Operation	Forward(Clockwise rotation) ,Reverse(Counter clockwise rotation),Reciprocation
Reciprocating angle range	10° ~270°, Adjustable
Operating conditions	Use: in enclosed spaces Ambient temperature: 0° C ~ 40° C Relative humidity: 10-85%RH Operating altitude < 3000m above sea level Atmospheric pressure: 70kPa ~ 106kPa
Transport and storage conditions	Ambient temperature: 0° C ~ 40° C Relative humidity: 10% ~ 85%RH Atmospheric pressure: 70kPa ~ 106kPa

3. Parts Identification

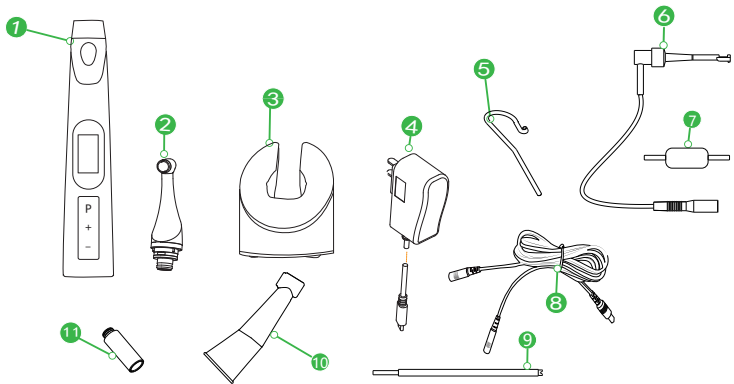

Components and Accessories

1 Main unit	1 (pc)	2 Contra angle	1 (pc)
3 Base	1 (pc)	4 Adapter	1 (pc)
5 Lip hook	2 (pcs)	6 File clip	2 (pcs)
7 Tester	1 (pc)	8 Measuring Wire	1 (pc)
9 Probe	2 (pcs)	10 Insulating sleeve	2 (pcs)
11 Spray nozzle	1 (pc)		

4. Intended Use

ELITE-INO is a cordless endodontic treatment motorized handpiece with root canal measuring capability, using for endodontics during a root canal treatment, to drive instruments for shaping in continuous rotation and reciprocating movement with torque and speed control.

The device must be only used by or under instruction of qualified medical personnel. The personnel who use the device must be trained.

FOR DENTAL USE ONLY !

5. Contraindications

This equipment is contraindicated in cases where patient/user carry medical implants such as pace makers or cochlear implants etc.

Do not use the device for implants or other non-endodontic dental procedures.

Safety and effectiveness have not been established in pregnant women and children.



Warning

Read the following warning before use:

1. The device must not be placed in humid surroundings or anywhere where it can come into contact with any type of liquids.

2. The device is intended for endodontic treatment and may only be used by trained and qualified professionals such as dentists in the hospital.

3. Do not expose the device to direct or indirect heat sources. The device must be operated and stored in a safe environment.

4. The device requires special precautions with regard to electromagnetic compatibility (EMC) and must be installed and operated in strict compliance with the EMC information. In particular, do not use the device in the vicinity of fluorescent lamps, radio transmitters, remote controls, portable or mobile RF communication devices, and do not charge, operate or store at high temperatures. Comply with the specified operating and storage conditions.

5. Gloves and a rubber dam are compulsory during treatment.

6. If irregularities should occur in the device during treatment, switch it off. Contact the agency.

7. Do not open or repair the device by yourself, otherwise, void the warranty.

6. Use Interface

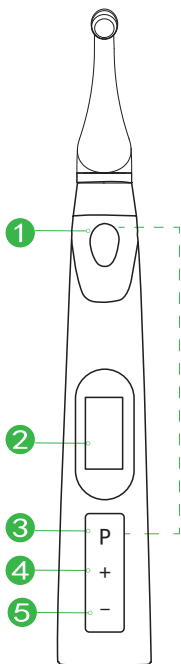

- ① Main switch
- ② Display screen
- ③ P button
- ④ Increase button
- ⑤ Decrease button

Turn device on

Press ① more than 0.8 seconds.

Memory Change

Press + and - to change memory.

Parameter Change

Press "P button" to select the parameters to be modified, and press + or - to adjust(parameters will be saved automatically when it changed).

Press ① **main switch** to exit.

User Setting

During power off mode,holding on "P button" and then press "main switch" to entry Advanced Setting mode.

Turn device off

Press ① and ③ at the same time to turn device off.

6.1 Display Screen

Apex Mode

This mode is for canal measurement.
*The motor do not run in this mode.

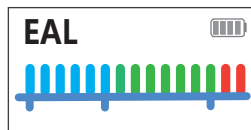

FWD Mode

The motor rotates forward 360°
Torque reverse and other functions can be used.

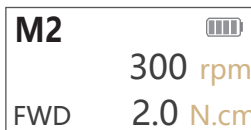

REC Mode

The motor runs reciprocating according to the angle.

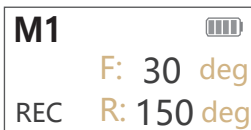

REV Mode

The motor rotates reverse 360° only.
Torque reverse and other functions **cannot be used**.
*In this mode , there is a certain frequency of beeps.

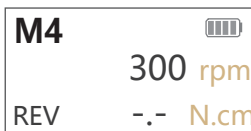

ACC Mode

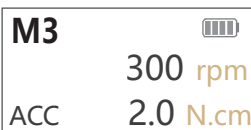

The motor rotates forward rotation (clockwise rotation), when the TORQUE is at about 70% of the setting torque for a long time, it will automatically reverse and resume forward rotation after the resistance disappears.

ATC Mode

M2	300 rpm	
ATC	2.0 N.cm	

The motor rotates forward rotation (clockwise rotation), when it reaches the setting torque, it starts to reciprocate and resumes normal rotation after the resistance disappears.

File System Mode

ProTaper Next	300 rpm	
XA	2.0 N.cm	
FWD		

There are many File System built in the device.

User Setting

User Setting
▶ Calibration
Resetting
Brightness

In this mode ,you can change the "User Setting " parameters below:

Calibration;
Resetting;
Volume;
Hand Mode;
Brightness.



NOTE

1. The device shuts down automatically after no operation for 8 minutes.

6.2 Display during Operation

Torque display

The bar on the screen shows the load on the file .The color will change with different load.

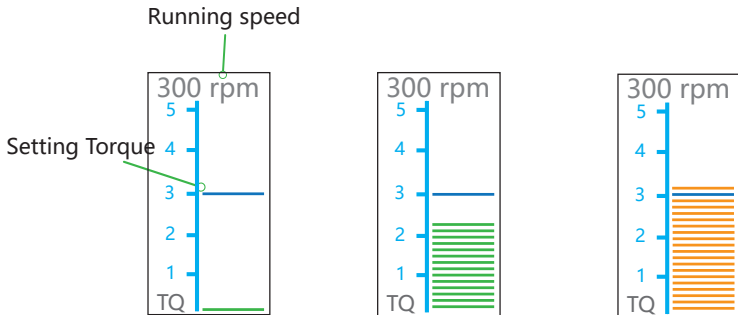

Canal measurement display

Bars in the meter show the location of the file tip. The color depending on location of the file tip inside the canal as shown below:

Meter Numbers



Warning

1. Meter numbers do not represent the actual length of the apical. These numbers are used to estimate the canal's working length.

7. Charging

Turn the device on by pressing the **1** button.

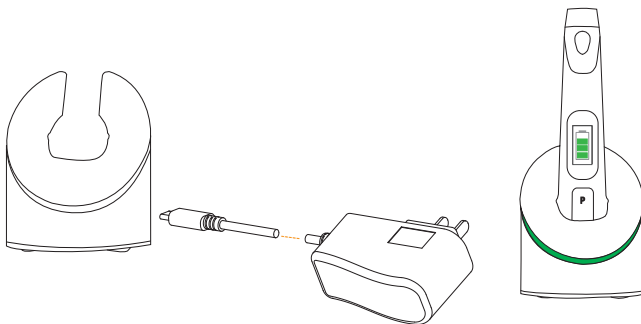

Connect the USB cable to the unit power connector, and plug the other end into a power outlet.

While charging, the battery symbols on the screen is displayed in sequence as bellow:

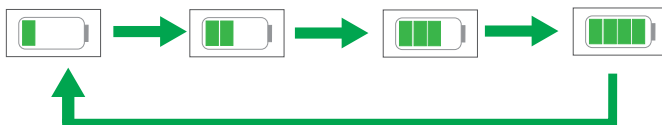

Fully charged will take about 4-5 hours, depending on residual battery power and the battery state.

When charging is completed, the battery symbols displays as :

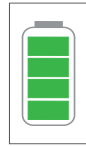

IF the power is too low, the battery indicator will show as:



Warning

1. Please charge the device for more than 4 hours before first use.
2. Only the original adapter and battery can be used.
3. Disposal of waste batteries in accordance with local regulations.
4. Do not use the device while charging.
5. Do not replace the battery. Only trained technicians or dealers can replace the battery. If the wrong battery is used or the installation method is wrong, the electronic components will be damaged.
6. Need to charge immediately, if the battery is low.

8. Install accessories

8.1 Connect Contra Angle

Make sure the pins on contra angle alignment the slots of handpiece, plug them together until it securely into place.

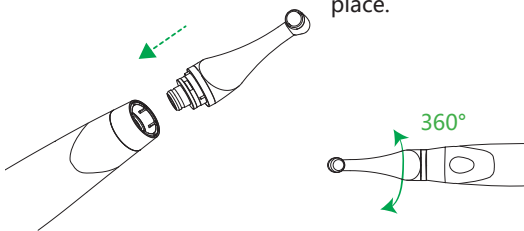

The contra angle can be 360° rotated without taking off, to make it easy to use during treatment.



Warning

1. Only the original contra-angle can be use.
2. After installing the contra-angle ,give it a light tug to make sure it is securely attached.

Using an insulating sleeve

It is recommend to use an insulating sleeve during combine apex.

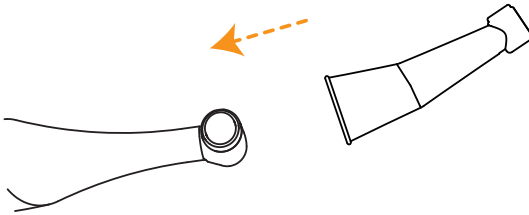

Warning

1. Without insulating sleeve,when performing the cannal measurement with handpiece, wear appropriate insulated gloves, and make sure the contra angle does not touch the lips It is advisable to use a rubber dam when performing such treatments.

8.2 Install the file

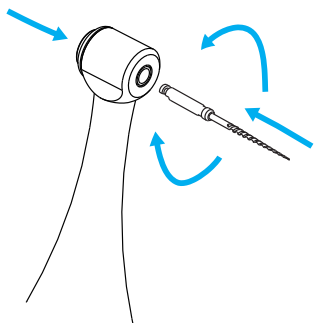

Hold down the push button on the contra angle and insert the file. Turn it back and forth until it is installed, and then release the button to lock the file into the contra angle.

Hold down the push button on the contra angle and remove the file carefully.

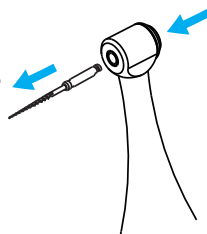

Warning

1. Make sure the motor is stopped before installing the file.
2. Inspect the file head before inserting it. Do not use the file which is damaged.
3. Insert the file gently to make sure it is securely installed.



NOTE

1. Insert or remove the file carefully to avoid finger injuries.
2. File removal without pressing the button may damage the file.

8.3 Install the measuring wire

*This is not required if the canal measurement function will not be used.

Connect the measuring wire to the motor handpiece and insert the lip hook and file clip into the other end of the measuring wire.

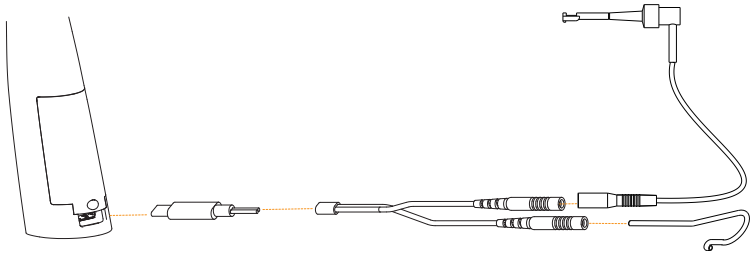

! NOTE

1. Make sure the plug is fully inserted. Otherwise canal measurements cannot be made.
2. Do not wind the measuring wire around the instrument.
3. After the measuring wire is installed, gently pull the measuring wire, lip hook and file clip to ensure that they are firmly connected.
4. Only the original accessories can be used.

! Warning

1. The replacement of lithium batteries or fuel cells by inadequately trained personnel could result in a hazard.
2. The hazards that can result from unauthorized modification of the device.
3. Random replacement of components may lead to unacceptable risks and hazards. If the user or agent need to replace components, please contact Shenzhen Rogin, Shenzhen Rogin will arrange professional maintenance personnel to provide services and provide information necessary for the safety of replacement components.

9. Before Operation

9.1 Check Motor

* Examples using default settings.

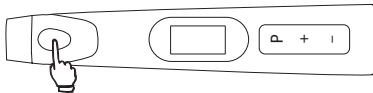

Press the Main switch to turn on the device.
The standby display will appear.

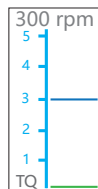
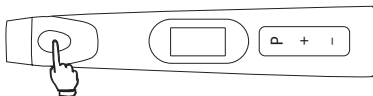

Press the Main switch and make sure the motor runs smoothly and press it again, the motor will stop, motor handpiece return to standby state.

*Torque meter will appear

9.2 Check Canal Measurement Function



Warning

Check the followings before start canal measurement function.

- 1.Measuring wire, lip hook and file clip are connected to the motor hand-piece.
- 2.Insulating sleeve has been installed.

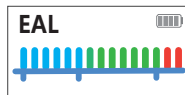
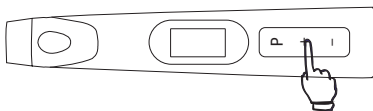

Press the + button to select the "EAL" mode during standby display.

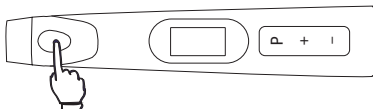

Press the Main switch to entry canal measurement.



*Apex meter will appear

Make file clip hook with lip hook (short circuit).

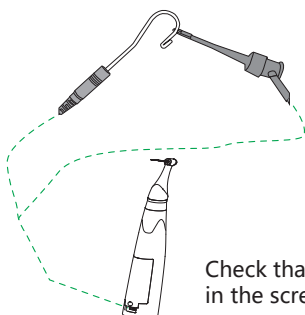

Check that all the indicator bars on the meter in the screen display light up.



Warning

Check the operation above before each treatment. If all the indicator bars do not light up, an accurate measurement cannot be made. In this case, stop using the device and contact your distributor.

9.3 Check with the Tester

After installing the measuring wire to the motor handpiece, plug the tester into the two sockets of the measuring wire and observe the number displayed on the screen. If it shows 02, 03 or 04.

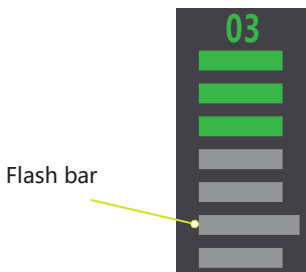
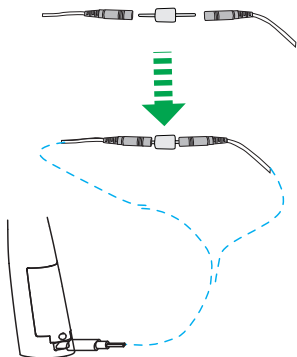



Warning

1. It is recommended to perform a test on the device every one or two weeks to ensure that the device is working well.
2. If s testing fails, stop using the device and contact your distributor.

9.4 Check Apex Function in Continuous rotation mode

* Examples using default settings.

Select (M2) memory, then press main switch.

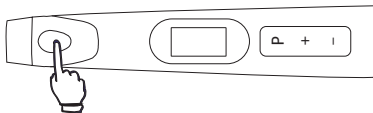

M2	
	300 rpm
FWD	2.0 N.cm

Make file on the contra angle with lip hook (short circuit).

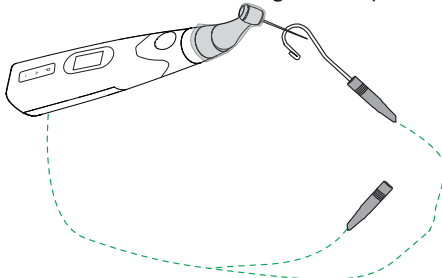

Check that all the indicator bars on the meter in the screen display light up.

9.5 Calibration

Warning

1. Install the original contra-angle into the device before calibrating.
2. Do not insert any file during calibrating.
3. When calibrating, do not touch the bending head to avoid affecting.
4. Ensure that the battery power is 50% or more before calibrating.
5. Only the original contra-angle can be used.

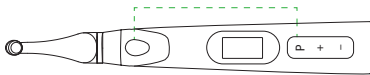

Press the **Main switch** and **P button** to entry User setting mode during off mode, press P button to select "**Calibration**".

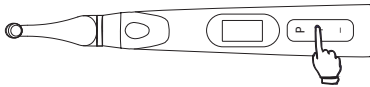

Press the + button to select "YES".

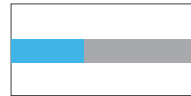
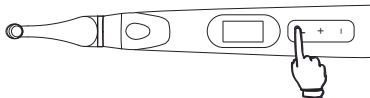

Press **P button** to start calibrating.

* Motor handpiece is automatically power off after finishing calibration.

Warning

Calibrate the device at the following times:

1. First time use after purchase.
2. Whenever the contra-angle has been replaced.

If the torque display of the handpiece still shows abnormality after calibration, please stop using it and contact your distributor.

10. Operation

10.1 Continuous rotation mode

*Press the Main switch to confirm and return standby mode.

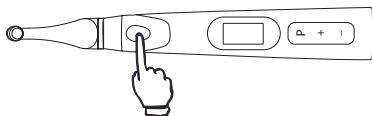

M2	
	300 rpm
FWD	2.0 N.cm

Press the **Main switch** to turn device on.

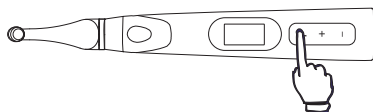

MOTION
FWD

Press the **P button** to change Motion setting, press + and - to adjust to **[REV] [FWD] [ACC] [ATC] [REV]**.

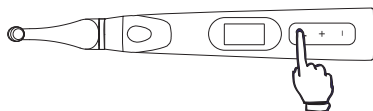

SPEED
300 rpm

Press the **P button** to change Speed setting, press + and - to adjust.

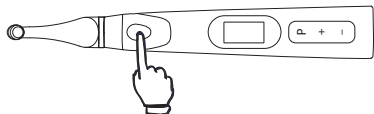

TORQUE
2.0 N.cm

Press the P button to change Torque setting, press + and - to adjust.

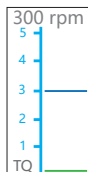
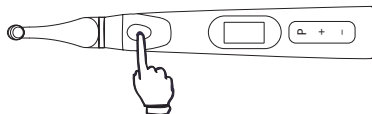

Press the Main switch to start / stop motor during standby mode.



NOTE

1. The device exits the current setting menu without any operation for a certain time in any parameter setting menu.
2. Please set the parameters according to the file manufacturer's recommendations.

10.2 Running with apex function

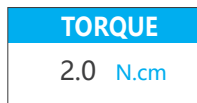
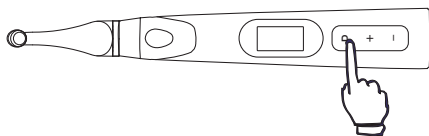

During standby state, Press P button until it shows "**Auto Start**" menu.

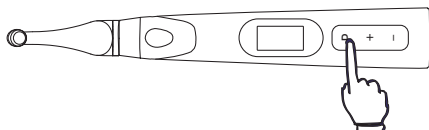

Press + and - to set it "**ON**" or "**OFF**", Press the select to the next parameter to be changed .

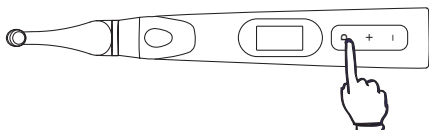

If "**Auto Start&Stop**" is enabled, the handpiece starts automatically when the file enters the root canal, and will stop automatically when leaving the root canal.

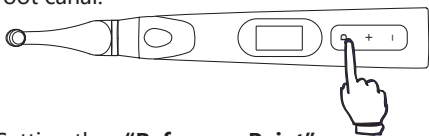

Setting the "**Reference Point**" .

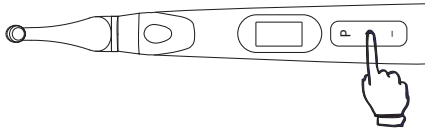

Apical Action

Slow Down

When this function is selected, the handpiece decrease the speed automatically when the file reaches the **Reference point**.

Apical Action

Reverse

If this function is selected ,the handpiece will rotate in the reverse rotation automatically when the file reaches the "**Reference Point**" ; and will resume the forward rotation. when it returns to the position above the "**06**" point

Components connection in continuous rotation mode with apex function:

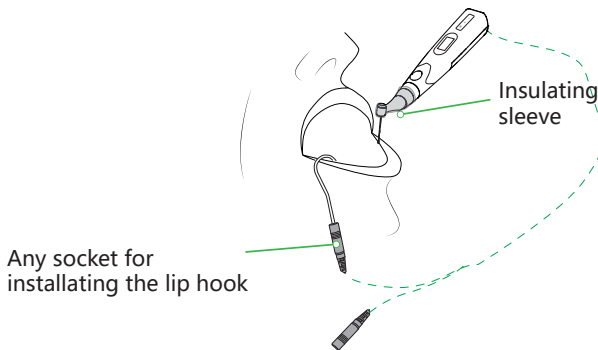

Using with the apex function, an insulating sleeve must be used.

10.3 Reciprocating mode

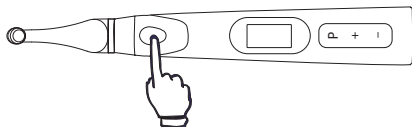

Press the + or - to select "REC" mode during standby .

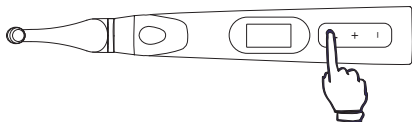

Press the P button to change Forward Angle setting, press + and - to adjust.

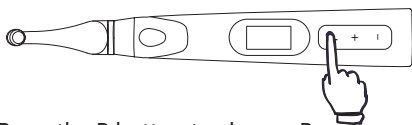

Press the P button to change Reverse Angle setting, press + and - to adjust.

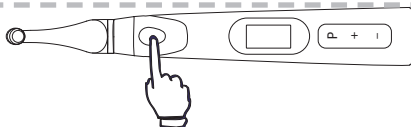

Press the Main switch to start / stop motor during Reciprocating mode.



*Press the Main switch to confirm and return standby mode.

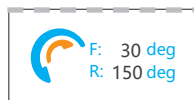

NOTE

Please set the parameters according to the recommendations of the document manufacturer.

10.4 Built in File System

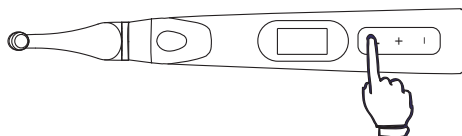

ProTaper Next		
XA	300 rpm	
FWD	2.0 N.cm	

Long press the P button to entry File Model Menu , then press P button to select file and exit.

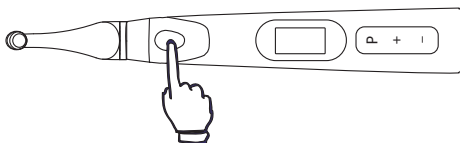

ProTaper Next		
▶ XA		FWD
X1	300 rpm	
X2	2.0 N.cm	

Press the **Main Switch** during File Model Menu to entry File Series Menu.

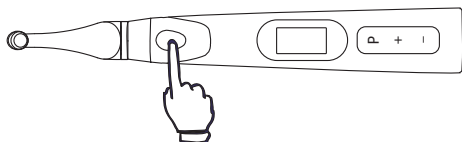

Dentsply	
▶ ProTaper Next	
ProTaper Gold	

Press the **Main Switch** during File Series Menu to entry File Brand Menu.

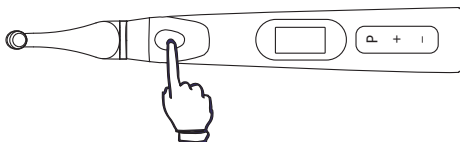

File System	
▶ User M0	
Dentsply	
VDW	

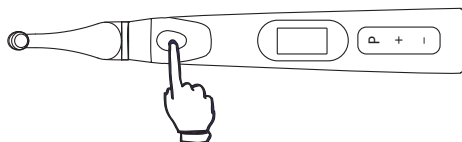

ProTaper Next		
XA	300 rpm	
FWD	2.0 N.cm	

Press the **Main Switch** during File Brand Menu to return to the File system mode.

NOTE

1. Changing the default setting is not recommended, only if user is sure that it can be changed. Otherwise, it risks file broken.
2. Please set the parameters according to the file manufacturer' s recommendations.
3. The parameter of the file selected can also be changed but not saved.

10.5 Canal measurement mode



Warning

Check the followings before making canal measurement function.

1.Measuring wire, lip hook and file clip are connected to the motor handpiece.

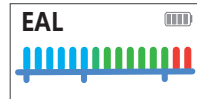
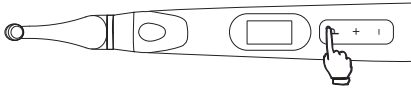

Press the + or - to select "EAL" .

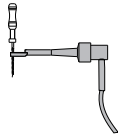
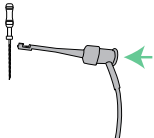

Clip the file clip to the metal shaft the file. Press in direction of arrow and clip file, then release to finish installation

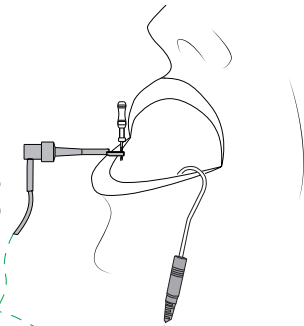
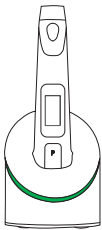

Connect the lip hook to the patient' s lower lip and the file clip to the file that is inserted into the treated root canal. The progression of the file into the canal in reference to the apex will be indicated on the display.

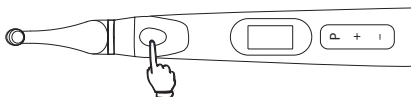

Press the Main switch to make a measurement.





Warning

Make sure that the connection between the root canal ,lip hook and the file clip is reliable, otherwise cannot make a measurement.

The following conditions are not suitable for root canal measurement:

- (1) Apical foreman of the root canal has be expanded;
- (2) The root canal which is bleeding or blood overflow apical foreman ;
- (3) The crown of the root canal is damaged;
- (4) The tooth root has cracks;
- (5) The root canal filled with gutta-percha;

Only the original accessories can be used.

Observing the strips and numbers indicated on the display while moving the file into the root canal slowly.

The numbers indicates the remaining number of strips before reaching the major apical foreman.

Strips become **Green** into the apical zone. The minor and major apical forename are separated by 7 strips form 00 to 06, **“00” will display when the major apical foreman is reached and the beep will sound continuously.**

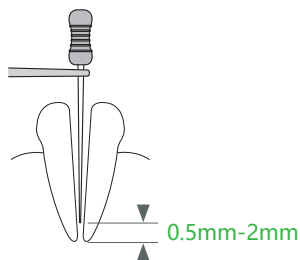
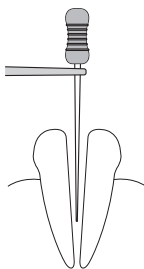

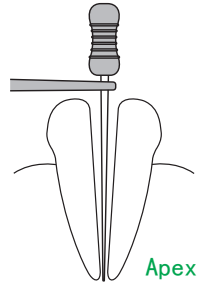
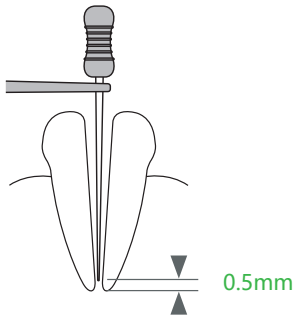

When the file tip over the apex, strips become red ,number becomes negative and with a rapid beep.

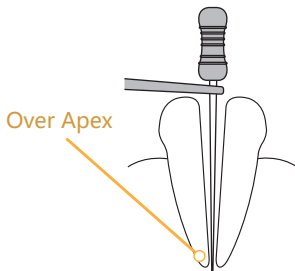



Warning

1. The "00" display means major apical foramen (not the minor apical foramen), in clinic the measure length need minus 0.5 to 1mm as the root canal length.
2. The device's screen do not show the actual length of the root canal ,the number reducing only means a trend that file move to apical .
3. In order to prevent the liquid from contacting the gum or the adjacent root canal to interfere with each other and cause the measurement error, the mouth should be dry before measurement.
4. The accessories which contact with patient (file folder, lip hook) can be reused ,and should be sterilized by high temperature before using every-time.
5. The measurement should be stopped and restarted when the file tip over the apex.

11. User Setting

Holding down "P" button and then press main switch to entry User setting during OFF state.

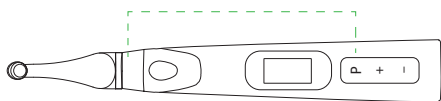

Press P button to entry "Calibration" in the User Setting Menu,and press + and - to adjust current selection .



About "Calibration" refer to section "**Calibration**"

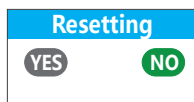

The handpiece can be factory reset and the following parameters restored to the factory defaults:

- 1.Memory program setting
2. User settings



Setting the Beep Volume.



Setting the left or right hand operation mode.

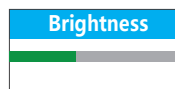

Changing the backlight brightness.



NOTE

1. The brightness reduces after 20 seconds without any operation. Press any button to restore the setting brightness.

12. Error Warring



The power is very low, charge it immediately.



It means that a large load happened greater than the motor force. Press the Main switch to restart motor.

13. Maintenance and sterilization





13.1 Foreword

For hygiene and sanitary purpose, the components must be cleaned, disinfected and sterilized before each usage to prevent any contamination. This occurs the first use as well as the subsequent uses.

Comply with your national guidelines, standards and requirements for cleaning, disinfection and sterilization.

13.2 General recommendations

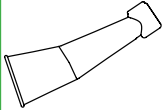
1. The user is responsible for the sterility of the product for the first cycle and each further usage as well as for the usage of damaged or dirty instruments, where applicable after sterility.
2. For your own safety, please wear personal protective equipment
3. Use only a disinfecting solution which is approved for its efficacy (VAH/ DGHM listing, CE marking, and FDA approval) and in accordance with DFU of the disinfecting solution manufacturer.
4. The water quality has to be convenient to the local regulations especially for the last rinsing step or with a washer-disinfector.
5. Thoroughly clean and wash the components before autoclaving.
6. Do not lubricate the motor handpiece.
7. Do not clean the contra angle with an ultrasonic cleaning device.
8. Do not use bleach or chloride disinfectant materials.

13.3 Autoclavable Components			
Contra-Angle 	File clip 	Lip hook 	Insulating Sleeve 
Probe 			



Warning

1. Only the components above can be autoclaved.
2. Before first use and after each use, sterilize the above components.

13.4 Cleaning and disinfection

Step	Operation	Processing
1	Preparation	Disconnect the components from the motor handpiece. Store the instruments in a humid surrounding.
2	Transportation	Safe storage and transportation to the reprocessing area to avoid any damage and contamination to the environment.
3	Preparation for decontamination	The device must be reprocessed in disassembled state.
4	Pre-Cleaning	Do a manual pre-cleaning, until the components are visually clean. Submerge the components in a cleaning solution and flush the lumens with a water jet pistol with cold tap water for at least 10 seconds. Clean the surfaces with a soft bristle brush.
5	Cleaning	Preference is to be given to automated reprocessing methods, especially due to the better standardizing potential and industrial safety. Automated cleaning: Carefully put the components into the washer disinfectant on a tray and set the parameters as follows: <ol style="list-style-type: none"> 1. 4 min pre-washing with cold water (<40°C); 2. 5 min washing with a mild alkaline cleaner at 55°C . 3. 3 min neutralising with warm water (>40°C); 4. 5 min intermediate rinsing with warm water (>40°C)
6	Disinfection	Automated Thermal Disinfection in washer/ disinfectant under consideration of national requirements in regards to A0 value(Refer to EN 15883). A disinfection cycle of 5 mins disinfection at 93°C , has been validated for the device to achieve an A0 value of 3000.

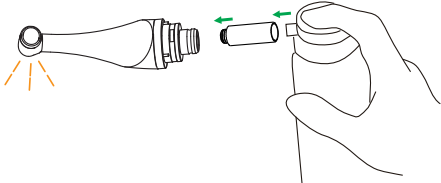
Step	Operation	Processing
7	Drying	Automated Drying: Drying of outside of instrument through drying cycle of washer/disinfecter. If needed , additional manual drying can be performed through lint free towel. Insufflate cavities of instruments by using sterile compressed air.
8	Maintenance	Inspect components and sort out those with defects.Dirty components must be cleaned and disinfected again. Lubricate the contra angle: 
9	Packing	Pack those component in an appropriate packaging material for sterilization.
10	Sterilization	Steam sterilization at 135° C at least 4 minutes, or at 121° C at least 35 minutes.Minimum drying time after sterilization: 10 minutes
11	Storage	Keep the components in sterilization packaging in a dry and clean environment.



Warning

Use only Ethanol for Disinfection (Ethanol 70 to 80% vol.)

Use only approved autoclave devices according to EN 13060 or EN 285. The sterilization procedure must comply with ISO17665. Waiting for cooling before touching.

Check the packaging before using it (packaging integrity, no humidity and validity period), otherwise sterilize again.

Disinfection before first use and after each use.

13.5 Disinfection components

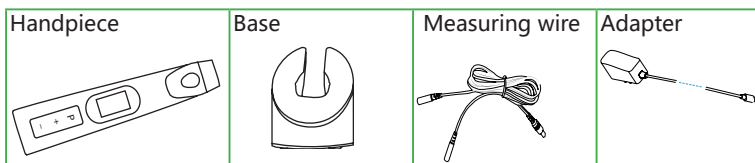

Wipe all the surfaces with a cloth lightly moistened with Ethanol for Disinfection (Ethanol 70 - 80vol%) at least 2min, repeat for 5 times.

 **NOTE**

1. Do not use anything except Ethanol for disinfection.

13.6 Battery Maintenance

Charge the battery when the battery icon shows red on the screen .

If you do not use the device for a long time, you need to keep the device fully charged at least once a month to ensure that the battery is not too low.

14. Troubleshooting

If trouble occurs during the use of the product, please check the following points before contacting your distributor.

Problem	Cause	Solution	Ref. chap
Cannot turn the device on	The battery is too low	Please charge	7
	Press the main switch button too short time	Press the button more than 0.8 seconds	/
There is no sound	Volume is setting off	Change the setting	11
	PCBA broken	contact your distributor	/
No displays on the screen	PCBA broken	contact your distributor	/
Cannot make a measurement	Measuring wire damage	Change another one	/
	Unstable connection between the wire and the file clip or lip hook	Check the connection	/
Cannot charge	Wrong adapter used	Use original adapter only	7

15. EMC table

Guidance and manufacturer's declaration – electromagnetic emissions		
The ELITE-INO is intended for use in the electromagnetic environment specified below. The customer or the user of the ELITE-INO should assure that it is used in such an environment.		
Emissions test	Compliance	Electromagnetic environment - guidance
RF emissions CISPR 11	Group 1	The ELITE-INO uses RF energy only for its internal function. Therefore, its RF emissions are very low and are not likely to cause any interference in nearby electronic equipment.
RF emissions CISPR 11	Class B	The ELITE-INO is suitable for use in all establishments, including domestic establishments and those directly connected to the public low-voltage power supply network that supplies buildings used for domestic purposes.
Harmonic emissions IEC61000-3-2	Class A	
Voltage fluctuations/ flicker emissions IEC 61000-3-3	Complies	

Guidance and manufacturer' s declaration –electromagnetic immunity

The **ELITE-INO** is intended for use in the electromagnetic environment specified below. The customer or the user of the **ELITE-INO** should assure that it is used in such an environment.

Immunity test	IEC 60601 test level	Compliance level	Electromagnetic environment - guidance
Electrostatic discharge (ESD) IEC 61000-4-2	+/- 8 kV contact +/- 2 kV, +/- 4 kV, +/- 8 kV, +/- 15 kV air	+/- 8 kV contact +/- 2 kV, +/- 4 kV, +/- 8 kV, +/- 15 kV air	Floors should be wood, concrete or ceramic tile. If floors are covered with synthetic material, the relative humidity should be at least 30%.
Electrical fast transients/ bursts IEC 61000-4-4	±2kV 100kHz repetition frequency	±2kV 100kHz repetition frequency	Mains power quality should be that of a typical commercial or hospital environment.
Surge IEC 61000-4-5	Line to line: ±0.5kV, ±1kV Line to earth: ±0.5kV, ±1kV, ±2kV	Line to line: ±0.5kV, ±1kV Line to earth: ±0.5kV, ±1kV, ±2kV	Mains power quality should be that of a typical commercial or hospital environment.
Electrostatic discharge (ESD) IEC 61000-4-2	+/-8 kV contact +/-2 kV, +/-4 kV, +/-8 kV, +/-15 kV air	+/- 8 kV contact +/-2 kV, +/-4 kV, +/-8 kV, +/-15 kV air	Floors should be wood, concrete or ceramic tile. If floors are covered with synthetic material, the relative humidity should be at least 30 %.
Voltage dips, Short interruptions and voltage variations on power supply lines IEC 61000-4-11	0% UT; 0.5 cycle at 0° , 45° , 90° , 134° , 180° , 225° , 270° , and 315° 0% UT; 1 cycle and 70% UT; 25/30 cycles sine phase at 0° 0% UT; 250/300 cycle	0% UT; 0.5 cycle at 0° , 45° , 90° , 134° , 180° , 225° , 270° , and 315° 0% UT; 1 cycle and 70% UT; 25/30 cycles sine phase at 0° 0% UT; 250/300 cycle	Mains power quality should be that of a typical commercial or hospital environment. If the user of devices require continue operation during power mains interruptions, it is recommended that devices be powered form an uninterruptible power supply or a battery

Immunity test	IEC 60601 test level	Compliance level	Electromagnetic environment - guidance
Power frequency magnetic field IEC 61000-4-8	30 A/m 50Hz or 60Hz	30 A/m 50Hz or 60Hz	Power frequency magnetic field should be at levels characteristic of a typical location in a typical commercial or hospital environment.

Note: UT: rated voltage(s); E.g.
25/30 cycles means 25 cycles at 50Hz or 30 cycles at 60Hz

Guidance and manufacturer' s declaration –electromagnetic immunity

The **ELITE-INO** is intended for use in the electromagnetic environment specified below. The customer or the user of the **ELITE-INO** should assure that it is used in such an environment.

Immunity test	IEC 60601 test level	Compliance level	Electromagnetic environment - guidance
Conducted disturbances induced by RF fields IEC 61000-4-6	3 V 0.15 MHz – 80 MHz, 6 V in ISM bands between 0.15 MHz and 80 MHz, 80 % AM at 1 kHz	3 V 3V/m Complies	Portable and mobile RF communications equipment should be used no closer to any part of the ELITE-INO , including cables, than the recommended separation distance calculated from the equation applicable to the frequency of the transmitter. Recommended minimum separation distances. See the RF wireless communication equipment table in "Recommended minimum separation distances".
Radiated RF EM fields IEC 61000-4-3	3 V/m, 80 MHz – 2,7 GHz, 80 % AM at 1 kHz See the RF wireless communication equipment table in "Recommended minimum separation distances"		
Proximity fields from RF wireless communication equipment IEC 61000-4-3	See the RF wireless communication equipment table in "Recommended minimum separation distances"		

Recommended minimum separation distances						
Nowadays, many RF wireless equipment have being used in various healthcare locations where medical equipment and/or systems are used. When they are used in close proximity to medical equipment and/or systems, the medical equipment and/or systems' basic safety and essential performance may be affected. The ELITE-INO has been tested with the immunity test level in the below table and meet the related requirements of IEC 60601-1-2:2014. The customer and/or user should help keep a minimum distance between RF wireless communications equipment and the ELITE-INO as recommended below.						
Test frequency (MHz)	Band (MHz)	Service	Modulation	Maximum power (W)	Distance (m)	Immunity test level (V/m)
385	380-390	TETRA 400	Pulse modulation 18Hz	1.8	0.3	27
450	430-470	GMRS 460 FRS 460	FM \pm 5 kHz deviation 1 kHz sine	2	0.3	28
710	704-787	LTE Band 13, 17	Pulse modulation 217Hz	0.2	0.3	9
745						
780						
810						
870	800-960	GSM 800/900, TETRA 800, iDEN 820, CDMA 850, LTE Band 5	Pulse modulation 18Hz	2	0.3	28
930						
1720						
1845	1700-1990	GSM 1800; CDMA 1900; GSM 1900; DECT; LTE Band 1, 3, 4, 25; UMTS	Pulse modulation 217Hz	2	0.3	28
1970						
2450	2400-2570	Bluetooth, WLAN, 802.11 b/g/n, RFID 2450, LTE Band 7	Pulse modulation 217Hz	2	0.3	28
5240	5100-5800	WLAN 802.11 a/n	Pulse modulation 217Hz	0.2	0.3	9
5500						
5785						

 **NOTE**

1. Use of accessories and cable other than those specified or provided by the manufacturer of the **ELITE-INO** could result in increased electromagnetic emissions or decreased electromagnetic immunity of **ELITE-INO** and result in improper operation.

Cable information			
Cable Name	Cable Length (m)	Shielded or not	Remark
Measuring wire	1.5	No	/
Adapter Cable	1.2	No	/

16. Warranty

1. The main unit of **ELITE-INO** enjoys a **12-month warranty period**, which starts on the day of delivery to the customer.
2. The host and other parts of the **ELITE-INO** are repaired by authorized repair service partners.
3. If it is proved that the damage is caused by improper daily maintenance by the user, it is not covered by the warranty.

17. Service life

The service life of the **ELITE-INO** main unit is **5 years**.

18. Declaration

In the following cases, the manufacturer does not assume any responsibility:

1. Use **ELITE-INO** for purposes other than those specified in this manual.
2. The cleaning, disinfection or sterilization operation is not carried out according to the method stated in this manual.
3. Use or maintenance by untrained personnel.
4. If you have any questions, please contact your local dealer.

19. Environmental protection

The package should be recycled. Metal parts of the device are disposed as scrap metal. Synthetic materials, electrical components, and printed circuit boards are disposed as electrical scrap. The lithium batteries are disposed as special refuse. Please deal with them according to the local environmental protection laws and regulation.

20. Right

All rights of modifying the product are reserved to the manufacturer without further notice. The pictures are only for reference. The final interpretation rights belong to the manufacturer. The industrial design, inner structure, etc, have claimed for several patents by the manufacturer, any copy or fake product must take legal responsibilities.

21. Warranty Card

Name of customer:	Tel:	Purchase date:
Address detail:		
Product name:	Model:	
Serial number:		
Maintenance record	Date	Fault cause

Thank you very much for using our products;This table is considered as the Protection to fix warranties,so please reserve them carefully,Loose don't repair

1. Calculated from the date of purchase,our company's product warranty period is **1_year**.During this any belongs to under normal usage circumstance cause because of the product.
Quality's problem of breakdown, our company will be responsible for giving free maintain.
2. In protect fix the period,if there is any breakdown,please return the faulty device and completed warranty card to our company for repair.
3. Those machines that has refitted or added other functions by yourself will not be accepted to repair.
4. Once the protect to fix card has been changed,the protection to fix immediately expired.

Free maintain won't be given under the following circumstance:

1. Without Protection to fix warranties.
- 2.Failure caused by improper installation,operation,and sterilization (Don't comply with the user manual).
3. The breakdown caused by the dismantle movement of non-our-company authorized maintain.
4. The damage caused by customer inappropriate preservation,maintain,break-down,or the usage.
5. Easy damage pieces and present accessories are not concerned.
6. The breakdown and the damage caused by the force majeure.

